

The information in this document is subject to change without notice and should not be construed as a commitment by ABB. ABB assumes no responsibility for any errors that may appear in this document.

Except as may be expressly stated anywhere in this document, nothing herein shall be construed as any kind of guarantee or warranty by ABB for losses, damages to persons or property, fitness for a specific purpose or the like.

In no event shall ABB be liable for incidental or consequential damages arising from use of this document.

This document and parts thereof must not be reproduced or copied without ABB's written permission, and contents thereof must not be imparted to a third party nor be used for any unauthorized purpose. Contravention will be prosecuted.

Additional copies of this document may be obtained from ABB at its then current charge.

© Copyright 2020 ABB ALL right reserved.

ABB

SE-721 68 Västerås
Sweden

Latest revision:



Lab/Office:
RA/RDP

CIRCUIT DIAGR.IRB390 MANIPULATOR
COPYRIGHT PAGE

Status:
APPROVED

Plant: =
Location: +
Sublocation: +

Document no.

3HAC060545-009

Rev. Ind

00

Page 1

Next 2
Total 14

Prepared by, date: PR, 2020-09-23

Approved by, date: JE, 2020-09-25

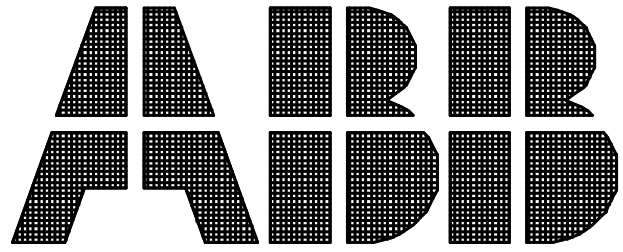

Description : CIRCUIT DIAGR.IRB390 MANIPULATOR
 Drawing number : 3HAC060545-009
 Drawing version : 00
 Date : 2020-09-25

Customer :
 Year of construction :
 :
 :
 :
 :
 :
 :

Drawn by : QMQT/PR
 Number of pages : 14
 :
 :
 :
 :

Latest revision:	Prepared by, date: PR, 2020-09-23	Approved by, date: JE, 2020-09-25	Lab/Office: RA/RDP	CIRCUIT DIAGR.IRB390 MANIPULATOR TITLE PAGE	Status: APPROVED	Plant: =	Rev. Ind	Page 2
					Document no. 3HAC060545-009	Location: +		
						Sublocation:+	Total 14	

we reserve all rights in this document and in the information contained therein. Reproduction, use or disclosure to third parties without express authority is strictly forbidden. © Copyright 2003 ABB

TABLE OF CONTENTS

PAGE	PAGE DESCRIPTION	Date	Edited by
1	COPYRIGHT PAGE	2020-09-23	QMQT/PR
2	TITLE PAGE	2020-09-23	QMQT/PR
3	TABLE OF CONTENTS	2020-09-23	QMQT/PR
4	LEGEND	2020-09-23	QMQT/PR
5	BLOCK DIAGRAM, IRB 390-10/1300	2020-09-23	QMQT/PR
6	BLOCK DIAGRAM, IRB 390-15/1300	2020-09-23	QMQT/PR
7	MOTOR POWER, AXIS 1-5. IRB 390-10/1300	2020-09-23	QMQT/PR
8	MOTOR POWER, AXIS 1-4. IRB 390-15/1300	2020-09-23	QMQT/PR
9	SERIAL MEASUREMENT BOARD	2020-09-23	QMQT/PR
10	RESOLVER FEED-BACK, AXIS 1-5. IRB 390-10/1300	2020-09-23	QMQT/PR
11	RESOLVER FEED-BACK, AXIS 1-4. IRB 390-15/1300	2020-09-23	QMQT/PR
12	OPTION RESOLVER CONNECTION, AXIS 7	2020-09-23	QMQT/PR
13	OPTION SAFETY LAMP	2020-09-23	QMQT/PR
14	OPTION EXTERNAL BRAKE RELEASE BOX	2020-09-23	QMQT/PR

we reserve all rights in this document and in the information contained therein. Reproduction, use or disclosure to third parties without express authority is strictly forbidden. © Copyright 2003 ABB

- G Battery
- H Lamp
- M Motor
- PE Protective Earth
- R Resolver
- SH Shield
- SP Splice Sleeve

 Functional equipotential bonding

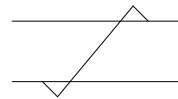
 Twisted conductors

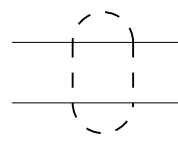
 Shielded conductors

 Free End

We reserve all rights in this document and in the information contained therein. Reproduction, use or disclosure to third parties without express authority is strictly forbidden. © Copyright 2003 ABB

Latest revision:		Lab/Office: RA/RDP	CIRCUIT DIAGR.IRB390 MANIPULATOR LEGEND	Status: APPROVED	Plant: = Location: + Sublocation: +	Document no. 3HAC060545-009	Rev. Ind 00	Page 4 Next 5 Total 14
Prepared by, date: PR, 2020-09-23	Approved by, date: JE, 2020-09-25							

We reserve all rights in this document and in the information contained therein. Reproduction, use or disclosure to third parties without express authority is strictly forbidden. © Copyright 2003 ABB

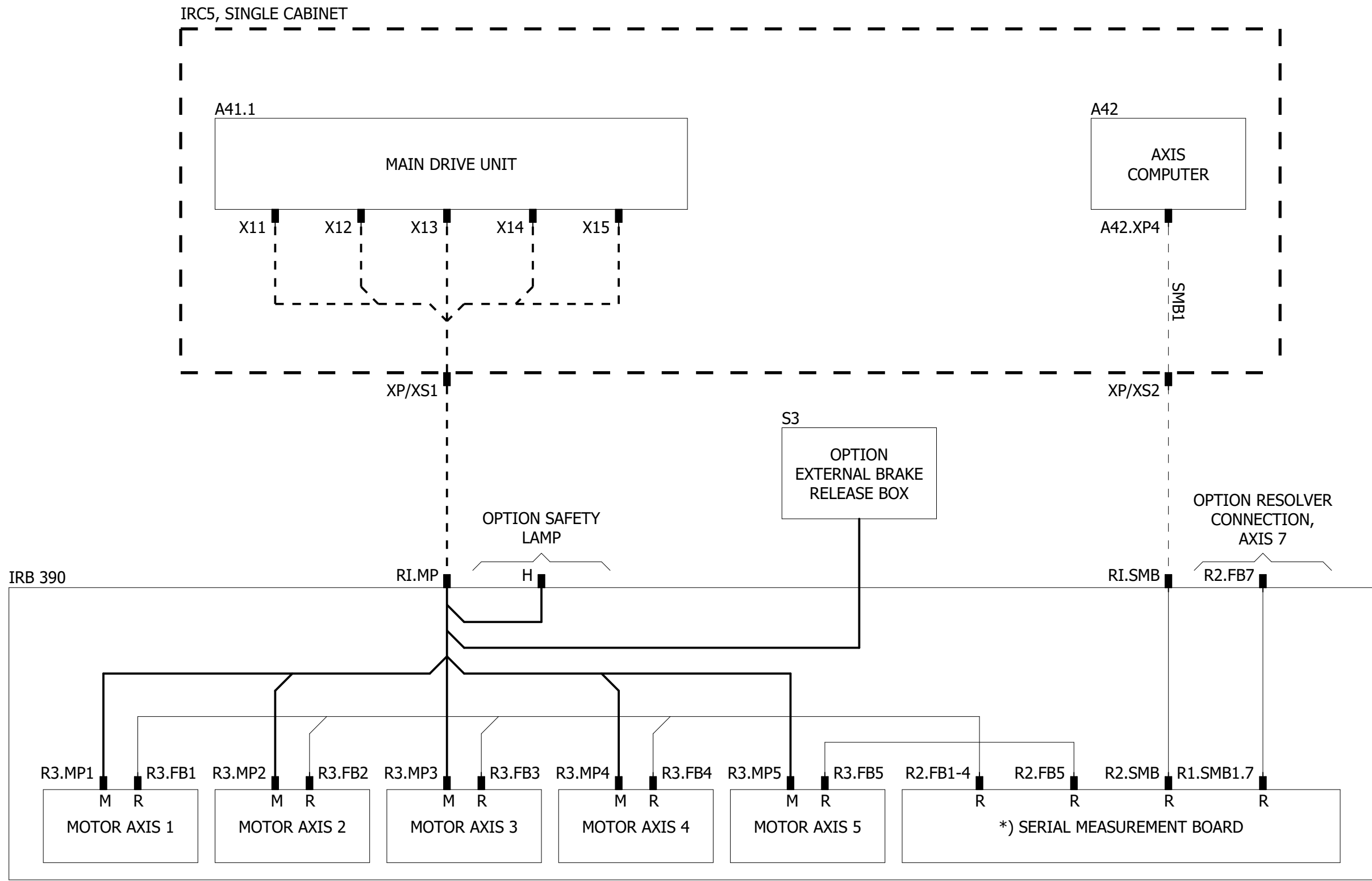

*) CONFIGURATION

MOTOR No.	SMB NODE No.	UNIT
M1	1	MOTOR AXIS 1
M2	2	MOTOR AXIS 2
M3	3	MOTOR AXIS 3
M4	4	MOTOR AXIS 4
M5	5	MOTOR AXIS 5

----- CONNECTION INCLUDED IN THE IRC5 CONTROLLER CIRCUIT DIAGRAM 3HAC024480-011

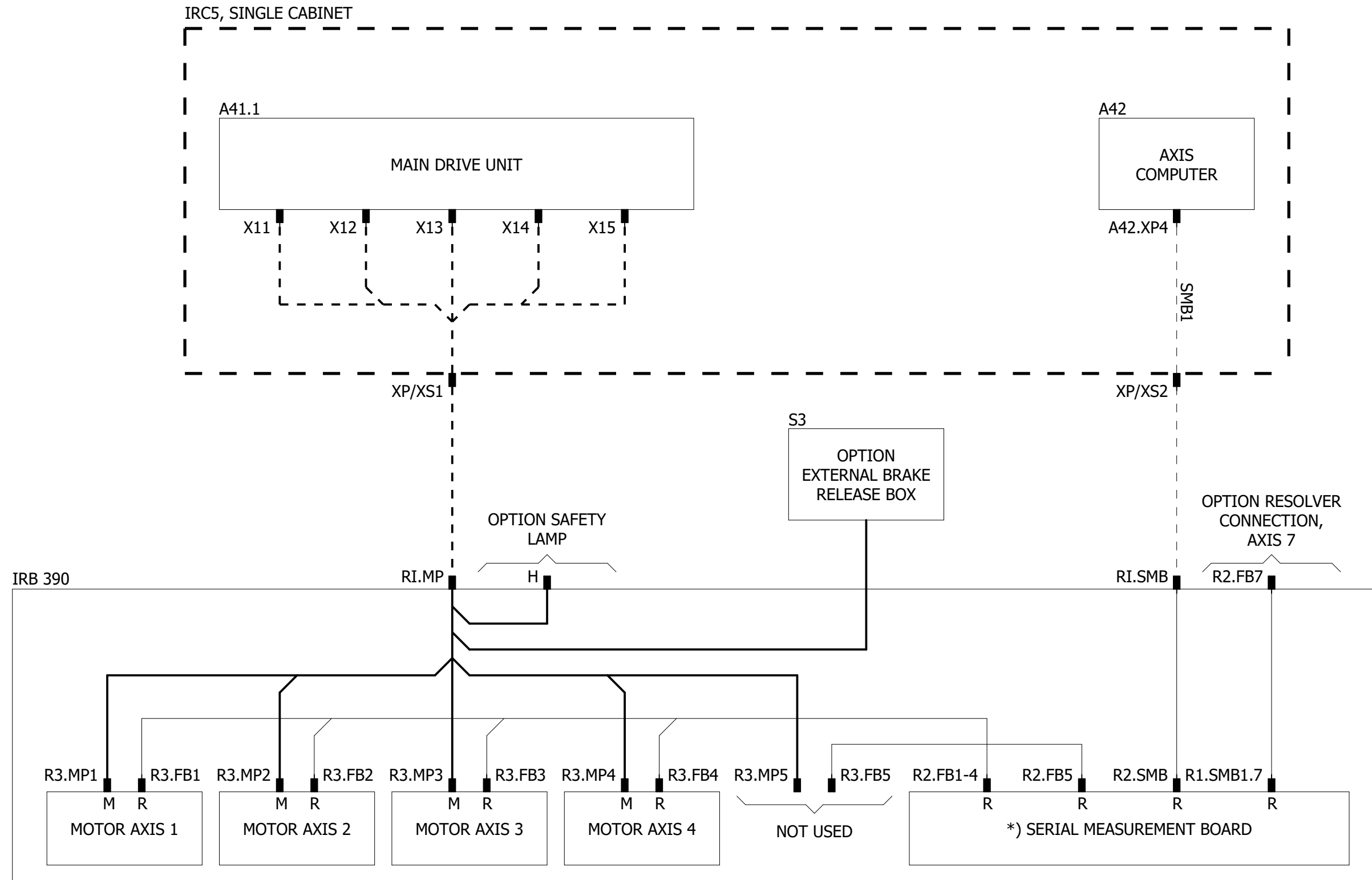

*) CONFIGURATION

MOTOR No.	SMB NODE No.	UNIT
M1	1	MOTOR AXIS 1
M2	2	MOTOR AXIS 2
M3	3	MOTOR AXIS 3
M4	4	MOTOR AXIS 4

----- CONNECTION INCLUDED IN THE IRC5 CONTROLLER
CIRCUIT DIAGRAM 3HAC024480-011

Latest revision:
Prepared by, date: PR, 2020-09-23 | Approved by, date: JE, 2020-09-25



Lab/Office:
RA/RDP

CIRCUIT DIAGR.IRB390 MANIPULATOR
BLOCK DIAGRAM, IRB 390-15/1300

Status:
APPROVED

Plant: =
Location: +
Sublocation: +

Document no.
3HAC060545-009

Rev. Ind Page 6
00 Next 7
Total 14

We reserve all rights in this document and in the information contained therein. Reproduction, use or disclosure to third parties without express authority is strictly forbidden. © Copyright 2003 ABB

SEE THE IRC5 CONTROLLER CIRCUIT DIAGRAM 3HAC024480-011

IRB 390

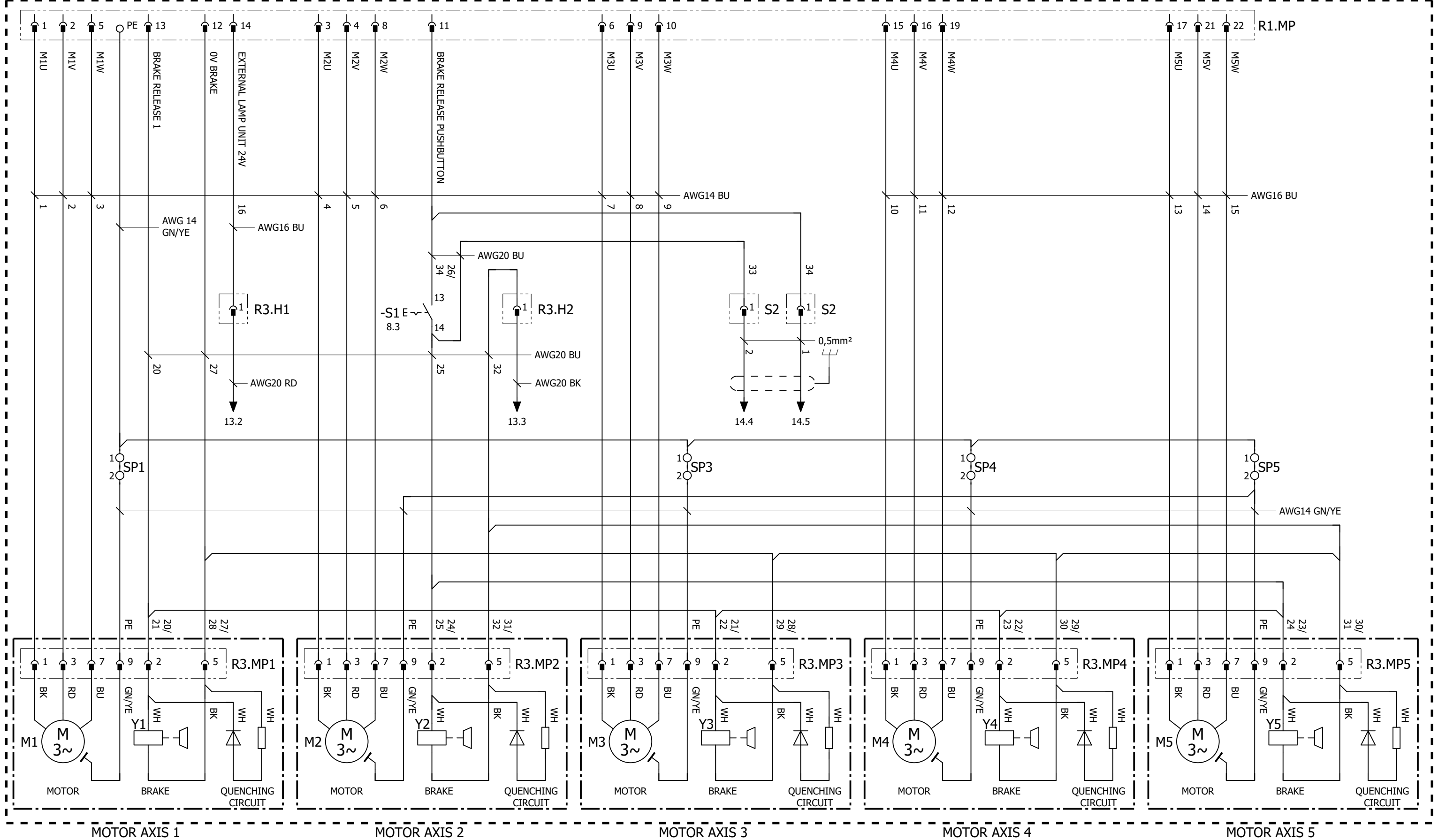

Latest revision:
 Prepared by, date: PR, 2020-09-23
 Approved by, date: JE, 2020-09-25

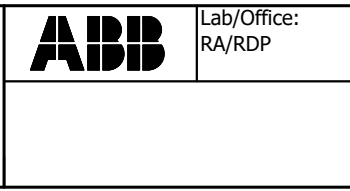



CIRCUIT DIAGR.IRB390 MANIPULATOR
 MOTOR POWER, AXIS 1-5.
 IRB 390-10/1300

Status: APPROVED
 Document no. 3HAC060545-009
 Plant: =
 Location: +
 Sublocation: +
 Rev. Ind 00
 Page 7
 Next 8
 Total 14

we reserve all rights in this document and in the information contained therein. Reproduction, use or disclosure to third parties without express authority is strictly forbidden. © Copyright 2003 ABB

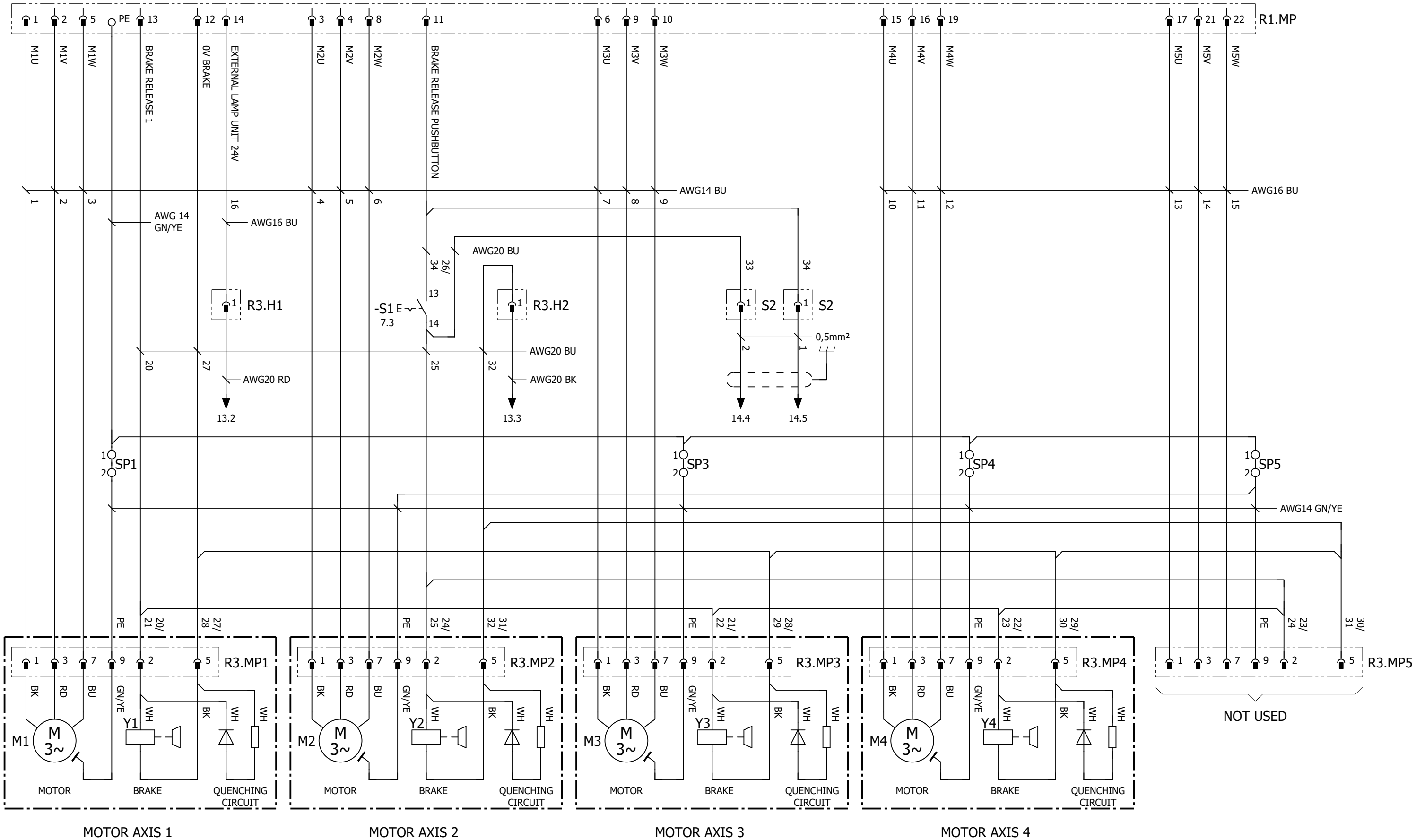
SEE THE IRC5 CONTROLLER CIRCUIT DIAGRAM 3HAC024480-011



Latest revision:	 Lab/Office: RA/RDP	CIRCUIT DIAGR.IRB390 MANIPULATOR MOTOR POWER, AXIS 1-4. IRB 390-15/1300	Status: APPROVED	Plant: = Location: + Sublocation: +
Prepared by, date: PR, 2020-09-23			Approved by, date: JE, 2020-09-25	Document no. 3HAC060545-009

we reserve all rights in this document and in the information contained therein. Reproduction, use or disclosure to third parties without express authority is strictly forbidden. © Copyright 2003 ABB

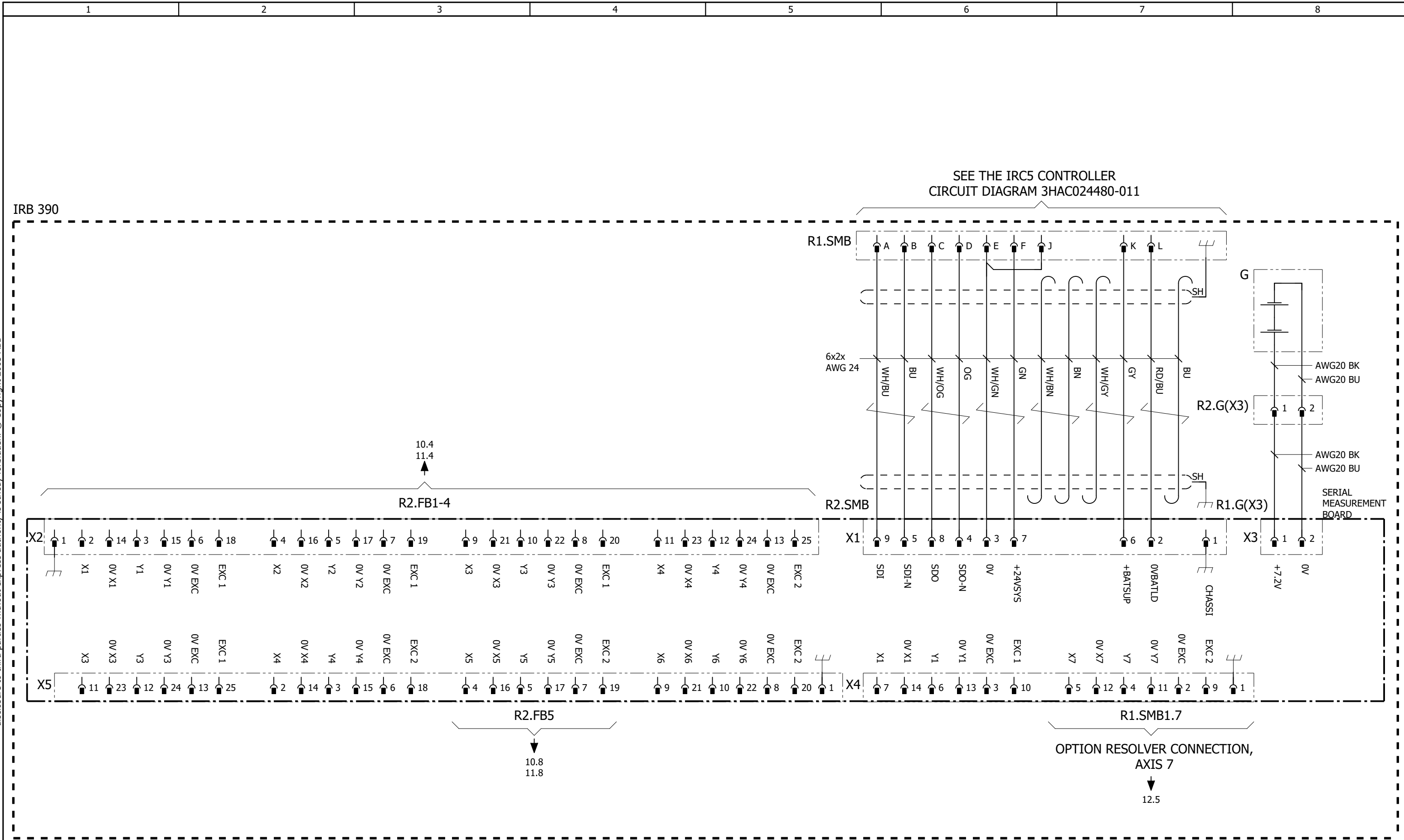

We reserve all rights in this document and in the information contained therein. Reproduction, use or disclosure to third parties without express authority is strictly forbidden. © Copyright 2003 ABB

Latest revision: Prepared by, date: PR, 2020-09-23			Lab/Office: RA/RDP	CIRCUIT DIAGR. IRB390 MANIPULATOR SERIAL MEASUREMENT BOARD	Status: APPROVED Document no. 3HAC060545-009	Plant: = Location: + Sublocation: + Rev. Ind 00	Page 9 Next 10 Total 14	
Approved by, date: JE, 2020-09-25								

IRB 390

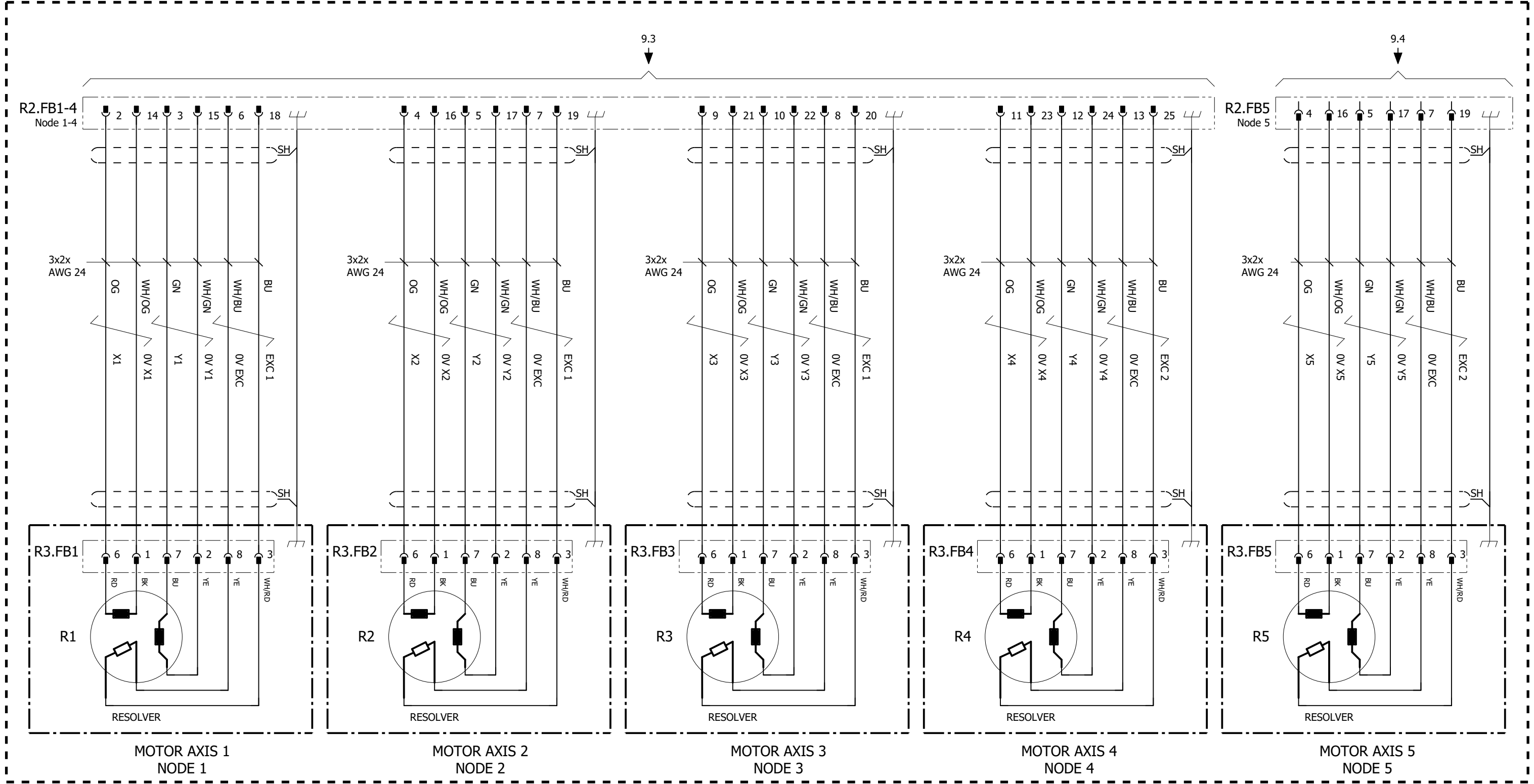

Latest revision:
 Prepared by, date: PR, 2020-09-23
 Approved by, date: JE, 2020-09-25

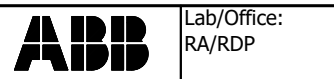

Lab/Office:
RA/RDP

CIRCUIT DIAGR. IRB390 MANIPULATOR
 RESOLVER FEED-BACK, AXIS 1-5.
 IRB 390-10/1300

Status:
APPROVED

Plant: =
 Location: +
 Sublocation: +

Document no.
3HAC060545-009

Rev. Ind Page 10
 00 Next 11
 Total 14

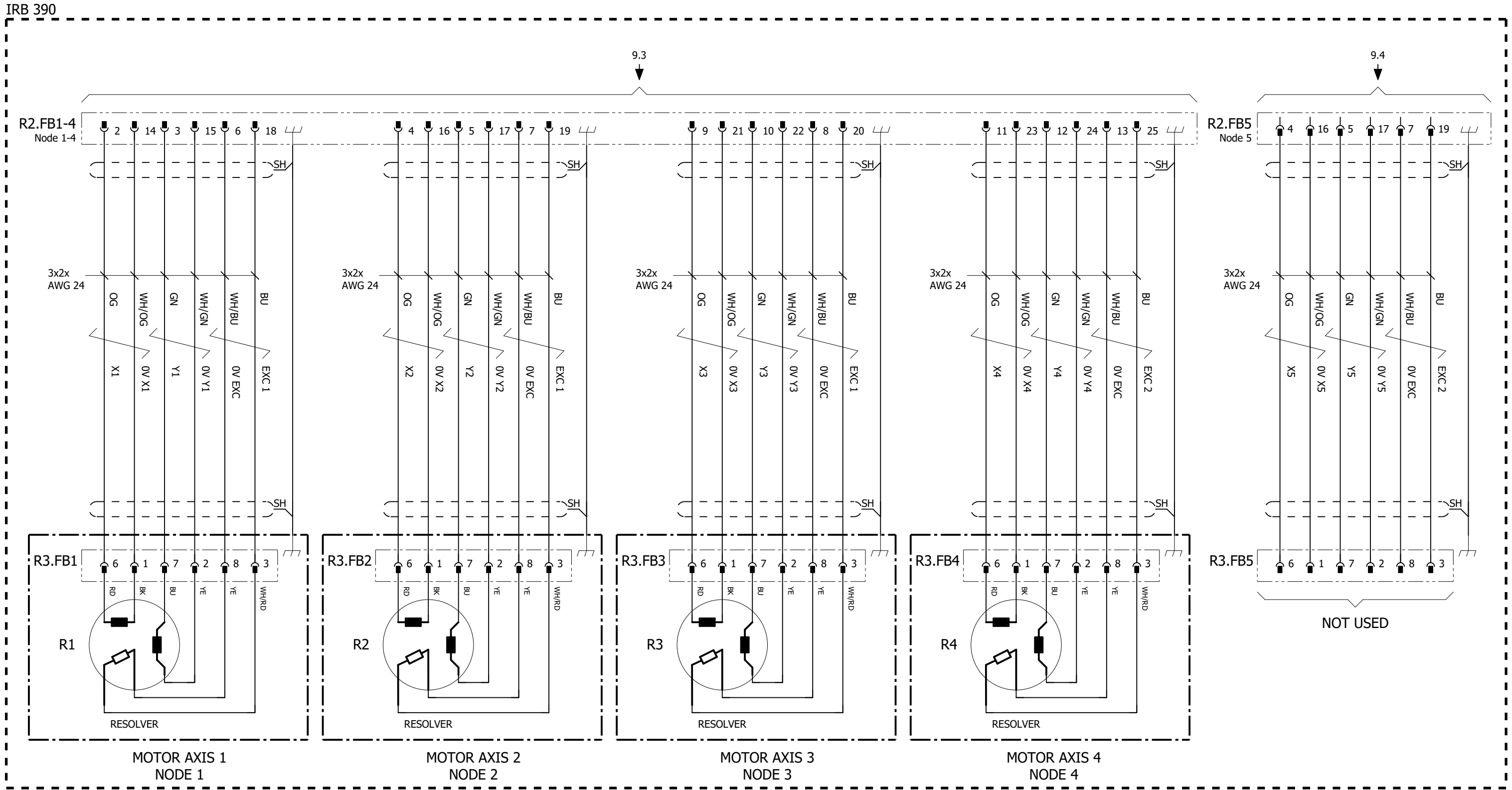

IRB 390

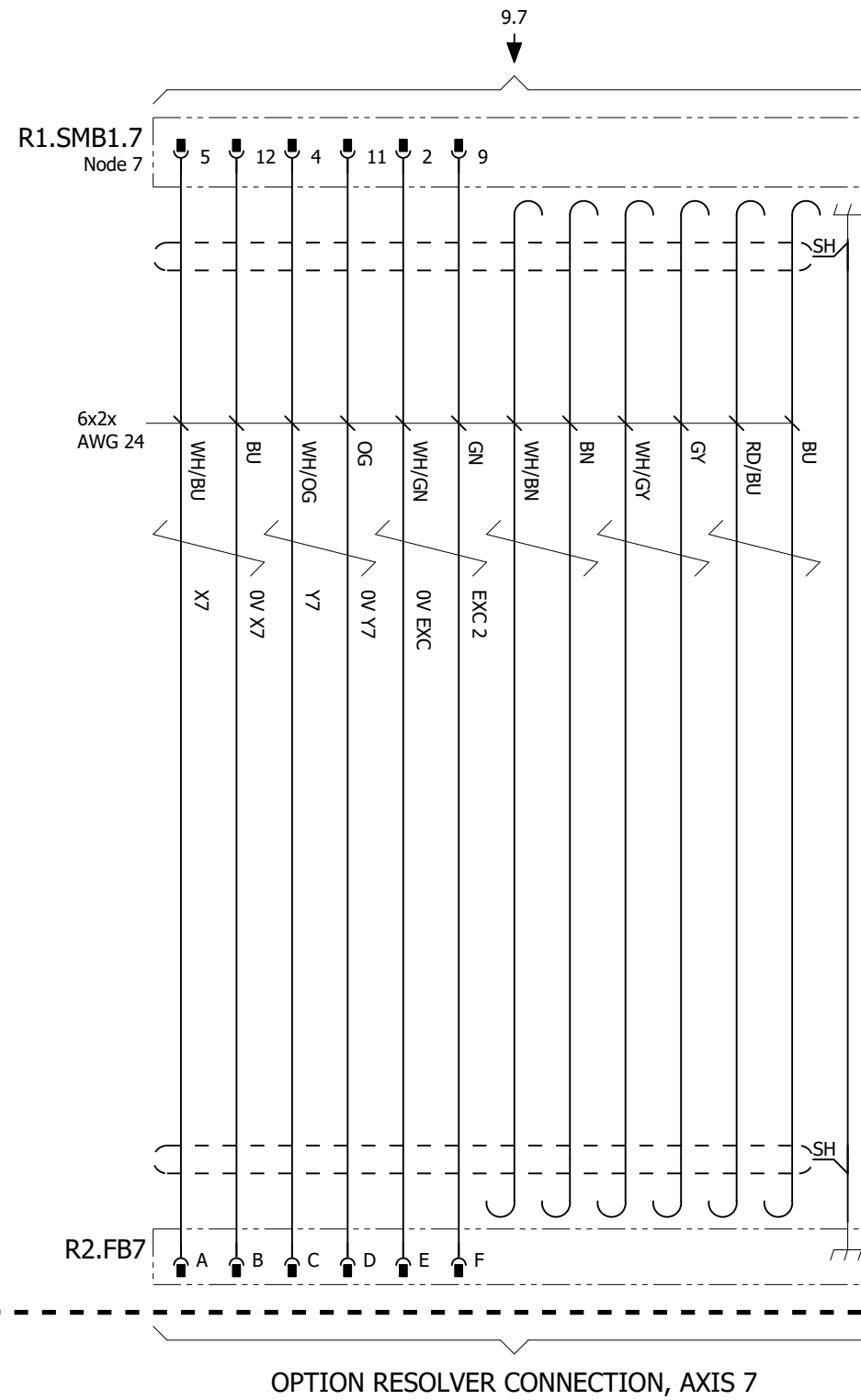

We reserve all rights in this document and in the information contained therein. Reproduction, use or disclosure to third parties without express authority is strictly forbidden. © Copyright 2003 ABB

Latest revision:

Prepared by, date: PR, 2020-09-23 | Approved by, date: JE, 2020-09-25



Lab/Office:
RA/RDP

CIRCUIT DIAGR. IRB390 MANIPULATOR
OPTION RESOLVER CONNECTION,
AXIS 7

Status:
APPROVED

Plant: =
Location: +
Sublocation: +

Document no.
3HAC060545-009

Rev. Ind
00

Page 12
Next 13
Total 14

IRB 390

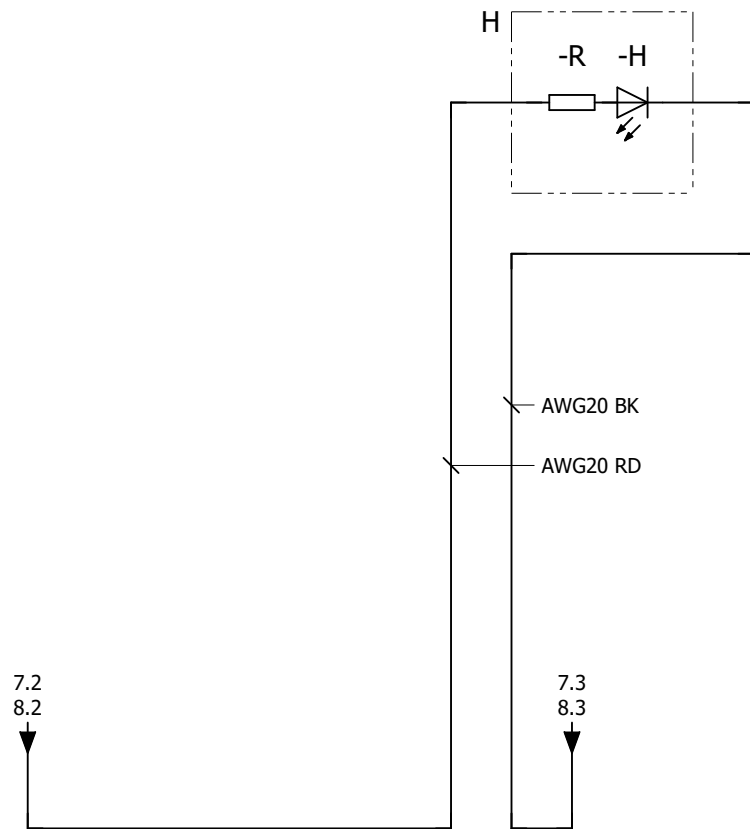

We reserve all rights in this document and in the information contained therein. Reproduction, use or disclosure to third parties without express authority is strictly forbidden. © Copyright 2003 ABB

Latest revision:

Prepared by, date: PR, 2020-09-23 Approved by, date: JE, 2020-09-25



Lab/Office:
RA/RDP

CIRCUIT DIAGR.IRB390 MANIPULATOR
OPTION SAFETY LAMP

Status:
APPROVED

Plant: =
Location: +
Sublocation: +

Document no.
3HAC060545-009

Rev. Ind
00

Page 13
Next 14
Total 14

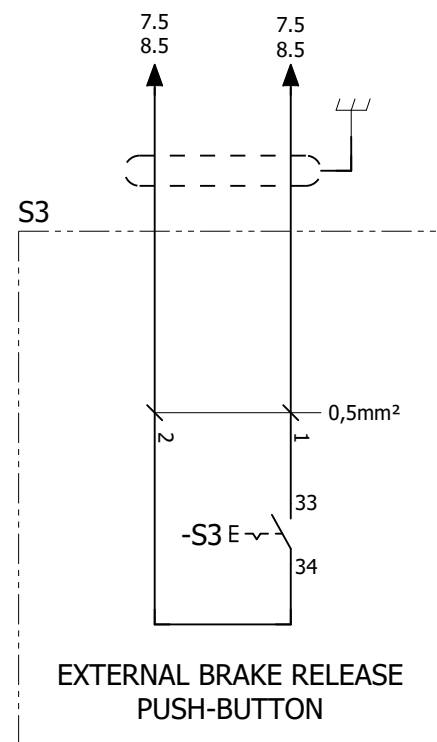

we reserve all rights in this document and in the information contained therein. Reproduction, use or disclosure to third parties without express authority is strictly forbidden. © Copyright 2003 ABB

Latest revision:

Prepared by, date: PR, 2020-09-23 | Approved by, date: JE, 2020-09-25



Lab/Office:
RA/RDP

CIRCUIT DIAGR. IRB390 MANIPULATOR
OPTION EXTERNAL BRAKE
RELEASE BOX

Status:
APPROVED

Plant: =
Location: +
Sublocation: +

Document no.
3HAC060545-009

Rev. Ind
00

Page 14
Next
Total 14